

3450

KERN 20  
PART SERVER 30

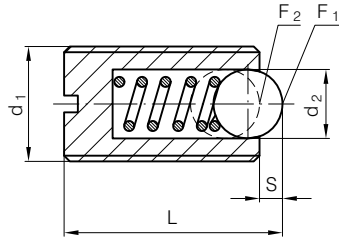

 3450 - d<sub>1</sub>

L	S	d <sub>2</sub>	F <sub>1</sub> (N)	F <sub>2</sub> (N)	d <sub>1</sub>
9	0,8	2,5	6	12	M4
12	0,9	3	7	13	M5
14	1	3,5	9	15	M6
16	1,5	5	20	35	M8
19	2	6	25	45	M10
22	2,5	8	35	60	M12
24	3,5	10	65	110	M16

3455

DIN 580

KERN 20  
PART SERVER 30

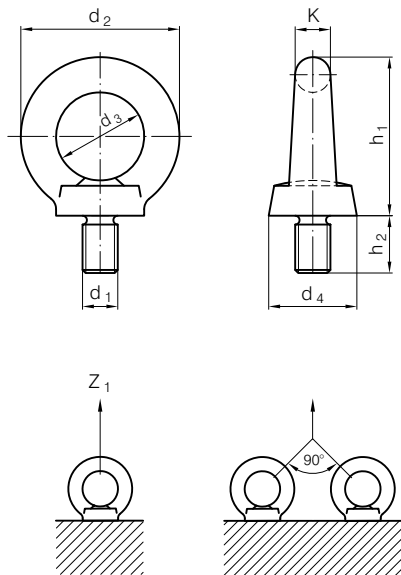

 3455 - d<sub>1</sub>

d <sub>2</sub>	d <sub>3</sub>	d <sub>4</sub>	h <sub>1</sub>	h <sub>2</sub>	K	Z <sub>1max</sub>	Z <sub>2max</sub>	d <sub>1</sub>
36	20	20	36	15	8	140	95	M 8
45	25	25	44,5	18	10	230	170	M 10
54	30	30	53	22	12	340	240	M 12
63	35	35	63,5	26	14	700	500	M 16
76	42	48	76	30	17	1200	830	M 20
90	50	56	90	35	20	1800	1270	M 24
106	56	65	107	45	24	3600	2600	M 30