

2340.3 H

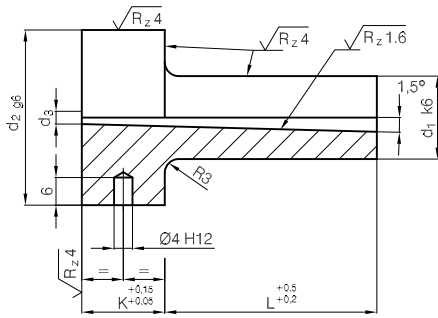

Mat.: 1.2826 54 ± 2HRc



2340.3 H - d₁ x L x d₃

K	d ₂	d ₁	L	d ₃
18	38	18	27	3,5
			36	
			46	
			56	
27	38	18	27	4,5
			36	
			46	
			56	

K	d ₂	d ₁	L	d ₃
18	38	18	56	4,5
			76	
23	48	24	46	6,5
			56	
			76	
			76	

2340.4 H

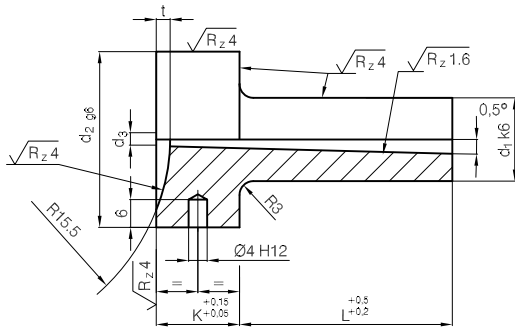

Mat.: 1.2826 54 ± 2HRc



2340.4 H - d₁ x L x d₃

t	K	d ₂	d ₁	L	d ₃
1,5	13	28	12	27	2,5
				36	
				46	
				56	
27	13	28	12	27	3,5
				36	
				46	
				56	
3,0	18	38	18	46	3
				56	
				66	

t	K	d ₂	d ₁	L	d ₃
3,0	18	38	18	76	3
				86	
				96	
				116	
3,0	18	38	18	46	4
				56	
				66	
				76	
3,0	18	38	18	86	4
				96	
				116	