

## 1251.1 ISO

ISO 9448-7 DIN 9831

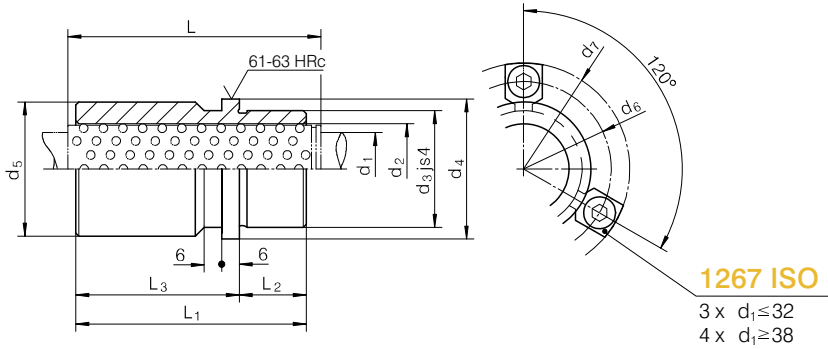

### ✍️ 1251.1 ISO - d<sub>1</sub>

L	L <sub>1</sub>	L <sub>2</sub>	L <sub>3</sub>	d <sub>7</sub>	d <sub>6</sub>	d <sub>5</sub>	d <sub>4</sub>	d <sub>3</sub>	d <sub>2</sub>	d <sub>1</sub>
71	59	23	36	64,7	52	39	40	32	25 26	19 20
95	79		56	72,7	60	46	48	40	30 31	24 25
120	93	30	63	79,7	67	53	56	48	38 40	30 32
	108	37	71	89,7	77	63	66	58	46 48	38 40
140	127	47	80	103,7	91	77	80	70	56 58	48 50
160	150	60	90	118,7	106	92	95	85	68 71	60 63
				141,7	129	115	118	105	92	80

## 1251.2 ISO

ISO 9448-7 DIN 9831

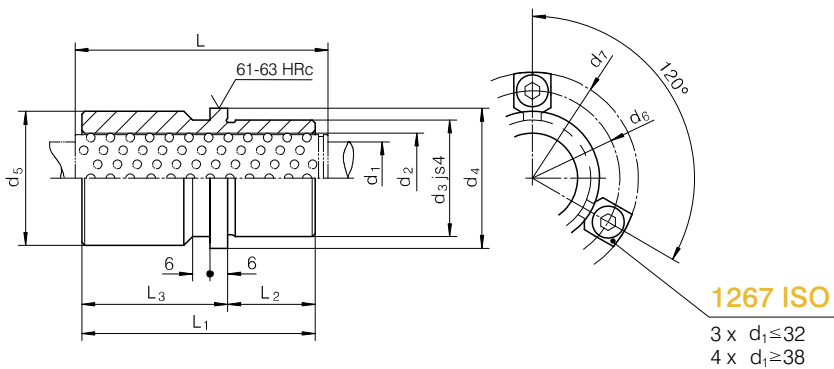

### ✍️ 1251.2 ISO - d<sub>1</sub>

L	L <sub>1</sub>	L <sub>2</sub>	L <sub>3</sub>	d <sub>7</sub>	d <sub>6</sub>	d <sub>5</sub>	d <sub>4</sub>	d <sub>3</sub>	d <sub>2</sub>	d <sub>1</sub>
95	80	30	50	72,7	60	46	48	40	30	24
									31	25
120	93	37	56	79,7	67	53	56	48	38	30
									40	32
140	110	47	63	89,7	77	63	66	58	46	38
									48	40
160	131	60	71	103,7	91	77	80	70	56	48
									58	50