

2340.5 H

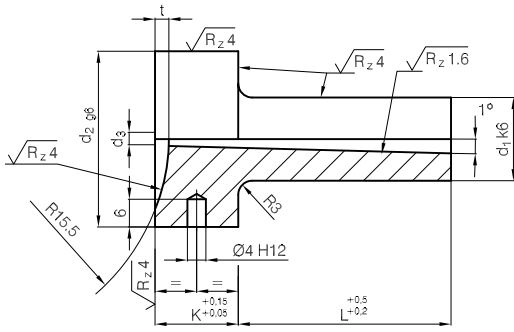

Mat.: 1.2826 54 ± 2HRc

✍️ 2340.5 H - d₁ x L x d₃

t	K	d ₂	d ₁	L	d ₃
1,5	13	28	12	22	2,5
				27	
				36	
				46	
				22	
3,0	18	38	18	27	3,5
				36	
				46	
				56	
3,0	18	38	18	27	3
				36	
				46	

t	K	d ₂	d ₁	L	d ₃
3,0	18	38	18	56	3
				76	
				96	
				116	
				27	
3,0	18	38	18	36	4
				46	
				56	
				76	
				96	
3,0	18	38	18	116	4
				116	

2340.6 H

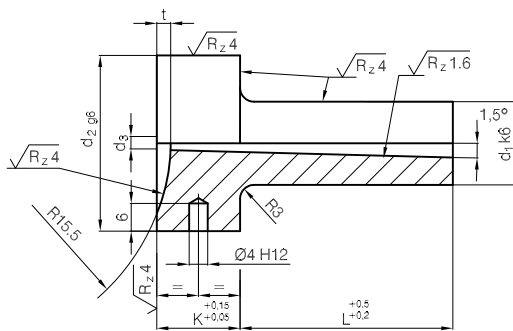

Mat.: 1.2826 54 ± 2HRc

✍️ 2340.6 H - d₁ x L x d₃

t	K	d ₂	d ₁	L	d ₃
3,0	18	38	18	27	3,5
				36	
				46	
				56	
				27	
3,0	18	38	18	36	4,5
				46	
				56	

t	K	d ₂	d ₁	L	d ₃
3,0	18	38	18	56	4,5
				76	
	23	48	24	46	
				56	
3,0	23	48	24	76	6,5
				76	